



## MECH FLOW SUPPLIES



Malleable Iron  
Pipe Fittings



Ductile Iron  
Grooved Fittings  
and Couplings



Valves



Cast Bronze  
Fittings



Electrical  
Power Fittings



Malleable Iron  
Pipe Clamps



Ductile Iron Pipe Fittings  
Cast Iron Pipe Fittings



Pipe Nipples



Fast Cambodia

Address: #2235, S/K khmounh, Khan Sen Sok, Phnom Penh, Cambodia

Phone: (855) 10 468 111 | (855)10 690 111

Email: [info@fastcambodia.com](mailto:info@fastcambodia.com)

[Http://www.fastcambodia.com](http://www.fastcambodia.com)

UPDATED 08/2018

# Malleable Iron Pipe Fittings

BS Standard

To Provide **Safe & Reliable** Products and **Smart & Complete**  
Solutions for Clients in Fluid Conveying Industry Across the Globe.



# More than 50 years of Foundry Experience

## Company Profile

Jinan Meide Casting Co. Ltd. was established in 1961. In the past decades, Jinan Meide has seized each opportunity to consolidate its strength, and has finally developed into what it is today, a large-scale enterprise group with advanced technology, equipment and strong comprehensive strength, known for its complete range of products, large producing capacity, high quality and strong R&D strength. The company owns altogether one main factory, three branch factories, two independent accounting steel pipe companies, and a science & technology park.

The company is the well-known manufacturer in the fitting industry with the most complete range of products, supplying malleable iron fittings, grooved fittings, grooved couplings, valves, cast iron fittings, ductile iron fittings, steel pipe nipples and couplings, stainless steel nipples, brass pipe nipples, cast bronze fittings, steel pipes, pipe hangers and supports, electric fittings, etc.

Over 50 years, Jinan Meide has been a trusted name in piping solutions by offering high-quality products, service and support to the PVF industry continuously. We provide expertise and product solutions for a wide range of applications, plumbing, mechanical, industrial, air-conditioning and refrigeration, mining, oil, gas, fire protection, equipment and power system. Many of the company's application technology are advanced in the world, with more than 20 patents registered each year, and the company has presided over and participated in the drafting of many important national standards of the industry.

We organize the whole production process in accordance with ISO 9001 and ISO 14001. It has also the most complete certificates in the PVF industry, including UL/FM/NSF of US, CRN/cUL of Canada, DVGW/TUV/CE/VdS of Germany, BSI/LPCB of UK, SII of Israel, JIS of Japan, ABNT of Brazil, GOST-R of Russia, CNBOP of Poland, KS of South Korea, TSE of Turkey, PSB of Singapore, SIRIM of Malaysia, SABS of South Africa etc. The products are well distributed in more than 130 countries and regions.

As an industry leader and key high-tech enterprise of the national torch plan, the company attaches great importance to environmental protection, energy-saving and emission-reduction. US-EEC recognizes MECH brand malleable iron pipe fittings as "the product to promote for the technology exchange of environmental protection". Protecting the environment is the duty of the company.

Customer satisfaction has always been the company's top objective, and we constantly stick to the principle: to provide customers with a value-added solution rather than simply delivering products.

# Company History

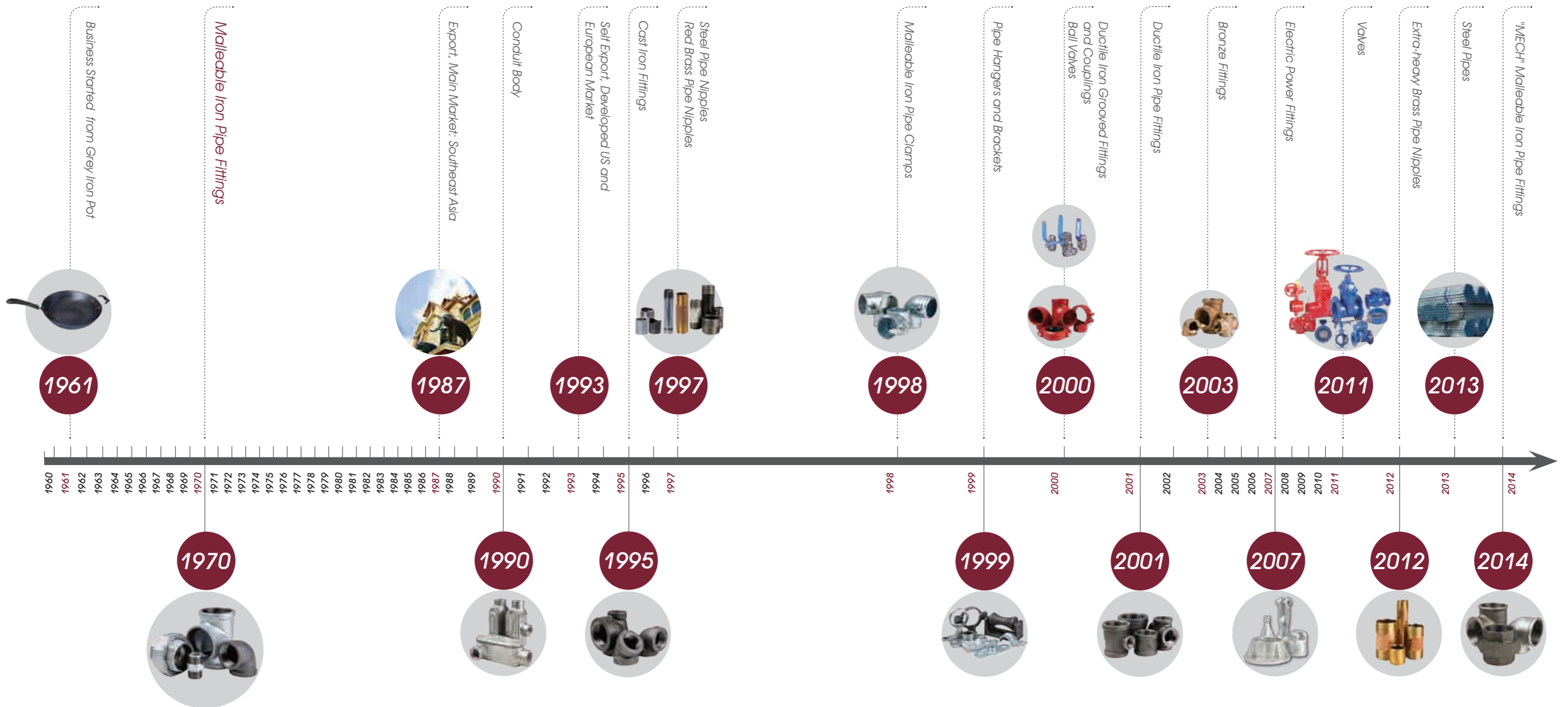

# State of the Art Equipment

High precision equipment is quality assurance. Jinan Meide's 8 factories are all equipped with the most advanced facilities and equipment in the industry. The main production facilities include Sinto automatic molding line, Tokyu automatic molding line, Chinese 416 automatic vertical molding line, automatic molding sand mixers, cupola furnaces, electric furnaces, water-cooled longevous cupola furnaces, CNC vertical machining centers, CNC machines, NC vertical lathes, radial drills, Jinan Meide proprietary automatic machines, hot-dipped galvanization line, automatic box sealing line, stereoscopic warehouse and so on.



Pattern



Core Making



Sand Mulling



Tokyu AMF-111055



DISA



Sinto FCMX



Melting



Pouring



Annealing



End Grinding Line



Warehouse



Threading, Air Pressure Test, and Anti-rust Treatment

# Reliable Quality Assurance

Jinan Meide is honored as the National enterprise technical center and is capable and qualified to conduct full series of tests and inspections including chemical checking, etc.

Inspection facilities include: spectrometer, carbon sulfur analyzer, metallurgical microscope, tensile strength testing equipment, pressure testing equipment, adhesive force testing equipment, CMM, hardness tester, etc.

From incoming inspection to finished product, quality is checked and monitored in the whole process. Each step of the manufacturing process is carefully documented, regularly reviewed for revision control and updating standard. Quality procedures are constantly monitored and updated to assure that only the highest and most consistent quality products are supplied to our valued customers.



Metallurgical Microscope



Spectrometer



CMM

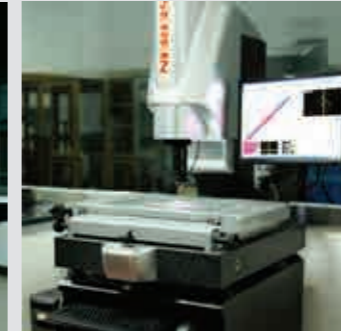

Projector

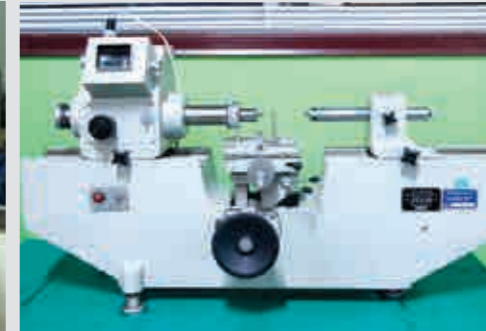

The Length of The Test Instrument

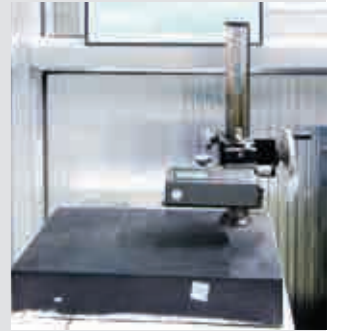

Roughness Tester



Carbon Sulfur Analyzer



Tensile Strength Testing Equipment



Sand Testing Instrument



# Certificates



# Malleable Iron Pipe Fittings

## BS Standard

Material: BS EN 1562  
Dimensions: BS EN 10242  
Threads: ISO 7-1  
Size Available: 1/8" - 6"



1#

Bend 90°, M/F

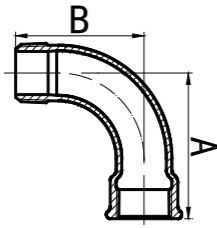

Size	Inch	1/8	1/4	3/8	1/2	3/4	1	1 1/4
	mm	6	8	10	15	20	25	32
Dim. (mm)	A	35	40	48	55	69	85	105
	B	32	36	42	48	60	75	95
Size	Inch	1 1/2	2	2 1/2	3	4	6	
	mm	40	50	65	80	100	150	
Dim. (mm)	A	116	140	176	205	260	365	
	B	105	130	165	190	245	345	

1#F

Bend 90°, M/F

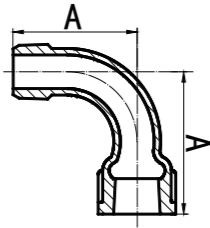

Size	Inch	1/2	3/4	1	1 1/4	1 1/2	2
	mm	15	20	25	32	40	50
Dim. (mm)	A	52	65	82	100	115	140
Size	Inch	2 1/2	3	4			
	mm	65	80	100			
Dim. (mm)	A	175	205	260			

1A

Short Bend 90°, M/F

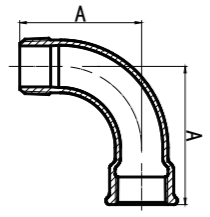

Size	Inch	1/4	3/8	1/2	3/4	1	1 1/4
	mm	8	10	15	20	25	32
Dim. (mm)	A	30	36	45	50	63	76
Size	Inch	1 1/2	2	2 1/2	3	4	
	mm	40	50	65	80	100	
Dim. (mm)	A	85	102	115	138	167	

1AF

Short Bend 90°, M/F

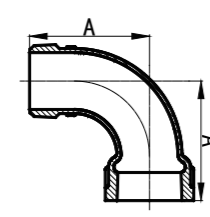

Size	Inch	1/4	3/8	1/2	3/4	1	1 1/4
	mm	8	10	15	20	25	32
Dim. (mm)	A	30	36	45	50	63	76
Size	Inch	1 1/2	2	2 1/2			
	mm	40	50	65			
Dim. (mm)	A	85	102	115			

2#

Bend 90°, female

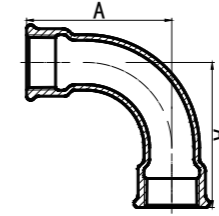

Size	Inch	1/4	3/8	1/2	3/4	1	1 1/4
	mm	8	10	15	20	25	32
Dim. (mm)	A	40	48	55	69	85	105
Size	Inch	1 1/2	2	2 1/2	3	4	
	mm	40	50	65	80	100	
Dim. (mm)	A	116	140	176	205	260	

2A

Short bend 90°, female

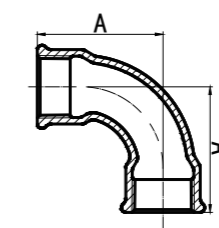

Size	Inch	1/2	3/4	1	1 1/4	1 1/2	2
	mm	15	20	25	32	40	50
Dim. (mm)	A	45	50	63	76	85	102
Size	Inch	2 1/2	3	4			
	mm	65	80	100			
Dim. (mm)	A	115	138	167			

2AF

Short bend 90°, female

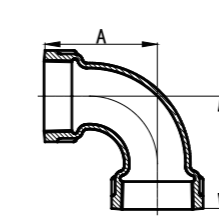

Size	Inch	1/4	3/8	1/2	3/4	1	1 1/4
	mm	8	10	15	20	25	32
Dim. (mm)	A	30	36	45	50	63	76
Size	Inch	1 1/2	2	2 1/2	3		
	mm	40	50	65	80		
Dim. (mm)	A	85	102	113	138		

3#

Bend 90°, male

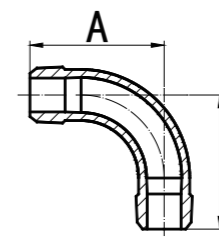

Size	Inch	3/8	1/2	3/4	1	1 1/4	1 1/2
	mm	10	15	20	25	32	40
Dim. (mm)	A	42	48	60	75	95	105
Size	Inch	2	2 1/2	3	4		
	mm	50	65	80	100		
Dim. (mm)	A	130	165	190	245		



40

Bend 45°, M/F

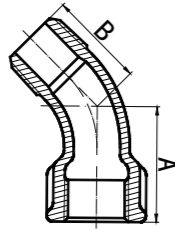

Size	Inch	1/4	3/8	1/2	3/4	1	1 1/4
	mm	8	10	15	20	25	32
Dim. (mm)	A	26	30	36	43	51	64
	B	21	24	30	36	42	54
Size	Inch	1 1/2	2	2 1/2	3	4	6
	mm	40	50	65	80	100	150
Dim. (mm)	A	68	81	99	113	142	197
	B	58	70	86	100	126	176

40F

Bend 45°, M/F

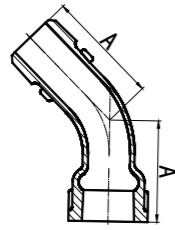

Size	Inch	3/4	1	1 1/4	1 1/2	2	2 1/2
	mm	20	25	32	40	50	65
Dim. (mm)	A	45	55	68	70	85	100
	B						
Size	Inch	3	4				
	mm	80	100				
Dim. (mm)	A	115	145				
	B						

41

Bend 45°, female

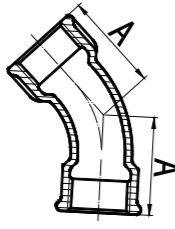

Size	Inch	1/4	3/8	1/2	3/4	1	1 1/4
	mm	8	10	15	20	25	32
Dim. (mm)	A	26	30	36	43	51	64
	B						
Size	Inch	1 1/2	2	2 1/2	3	4	6
	mm	40	50	65	80	100	150
Dim. (mm)	A	68	81	99	113	142	197
	B						

85

Crossover

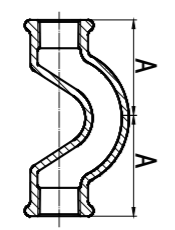

Size	Inch	1/2	3/4	1	1 1/4	1 1/2	2
	mm	15	20	25	32	40	50
Dim. (mm)	A	45	54	70	91	100.5	115
	B						
Size	Inch						
	mm						
Dim. (mm)	A						
	B						

90

Elbow, 90°

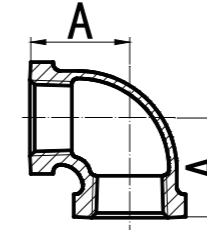

Size	Inch	1/8	1/4	3/8	1/2	3/4	1	1 1/4
	mm	6	8	10	15	20	25	32
Dim. (mm)	A	19	21	25	28	33	38	45
	B							
Size	Inch	1 1/2	2	2 1/2	3	4	5	6
	mm	40	50	65	80	100	125	150
Dim. (mm)	A	50	58	69	78	96	115	131
	B							

90R

Reducing Elbow, 90°

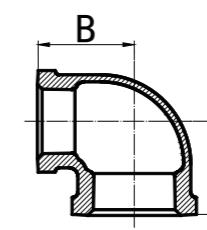

Size	Inch	4X1 1/4	4X1 1/2	4X2	4X2 1/2	4X3
	mm	100X32	100X40	100X50	100X65	100X80
Dim. (mm)	A	60	62	68	77	82
	B	85	85	86	89	90
Size	Inch	3/4X1/2	1X1/4	1X3/8	1X1/2	1X3/4
	mm	20X15	25X8	25X10	25X15	25X20
Dim. (mm)	A	30	27	30	32	35
	B	31	31	32	34	36

90R

Reducing Elbow, 90°

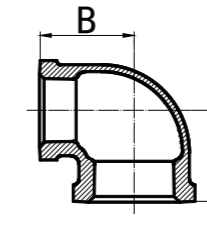

Size	Inch	3/8X1/8	3/8X1/4	6X4	1/2X1/4	1/2X3/8
	mm	10X6	10X8	150X100	15X8	15X10
Dim. (mm)	A	20.5	23	102	24	26
	B	21.5	23	125	24	26
Size	Inch	1 1/4X3/8	1 1/4X1/2	1 1/4X3/4	1 1/4X1	1 1/2X1/2
	mm	32X10	32X15	32X20	32X25	40X15
Dim. (mm)	A	32	32	36	40	34
	B	36.5	37	41	42	41

90R

Reducing Elbow, 90°

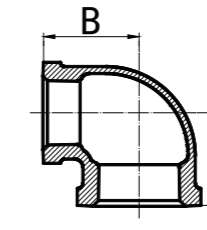

Size	Inch	3/4X1/4	3/4X3/8	1 1/2X1 1/4	2X1/2	2X3/4
	mm	20X8	20X10	40X32	50X15	50X20
Dim. (mm)	A	26	28	46	35	40
	B	27	28	48	47	48
Size	Inch	1 1/2X3/4	1 1/2X1	3X1	3X1 1/4	3X1 1/2
	mm	40X20	40X25	80X25	80X32	80X40
Dim. (mm)	A	37	42	50	53.5	56
	B	42	46	68	68	69

### 90R

Reducing Elbow, 90°

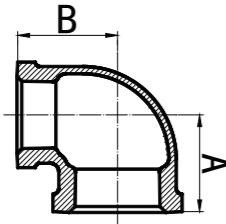

Size	Inch	2X1	2X1 1/4	2X1 1/2	2 1/2X3/4	2 1/2X1	2 1/2X2
	mm	50X25	50X32	50X40	65X20	65X25	65X50
Dim. (mm)	A	43	47	52	42.5	46.5	61
	B	50	53	56	57	58.5	66
Size	Inch	3X2	3X2 1/2	1 1/4X1/8	2 1/2X1 1/4	2 1/2X1 1/2	3X3/4
	mm	80X50	80X65	8X6	65X32	65X40	80X20
Dim. (mm)	A	60.5	71	18.5	50.5	53.5	45
	B	71	74	19	60	61	65

### 92

Street Elbow, 90°

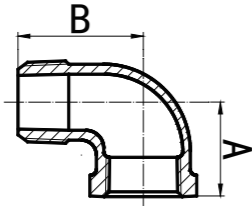

Size	Inch	1/8	1/4	3/8	1/2	3/4	1	1 1/4
	mm	6	8	10	15	20	25	32
Dim. (mm)	A	19	21	25	28	33	38	45
	B	25	28	32	37	43	52	60
Size	Inch	1 1/2	2	2 1/2	3	4	6	
	mm	40	50	65	80	100	150	
Dim. (mm)	A	50	58	69	78	96	127.5	
	B	65	74	88	98	118	202	

### 92R

Reducing Street Elbow, 90°

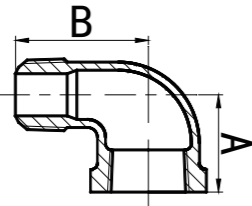

Size	Inch	3/4X1/2	1X3/4				
	mm	20X15	25X20				
Dim. (mm)	A	30	35				
	B	65.4	46				
Size	Inch						
	mm						
Dim. (mm)	A						
	B						

### 95

Union Elbow F/F

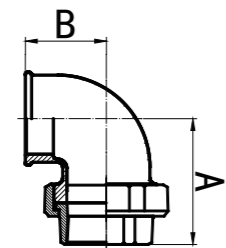

Size	Inch	1/2	3/4	1	1 1/4	1 1/2	2
	mm	15	20	25	32	40	50
Dim. (mm)	A	28	33	38	45	50	58
	B	58	62	72	82	90	100
Size	Inch						
	mm						
Dim. (mm)	A						
	B						

### 96

Union Elbow F/F

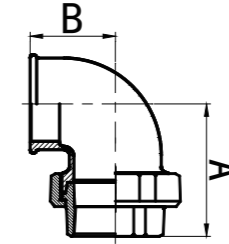

Size	Inch	1/2	3/4	1	1 1/4	1 1/2	2
	mm	15	20	25	32	40	50
Dim. (mm)	A	58	62	72	82	90	100
	B	28	33	38	45	50	58
Size	Inch						
	mm						
Dim. (mm)	A						
	B						

### 97

Union Elbow M/F

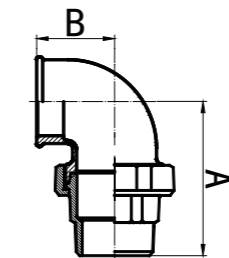

Size	Inch	1 1/2					
	mm	40					
Dim. (mm)	A	128					
	B	58					
Size	Inch						
	mm						
Dim. (mm)	A						
	B						

### 98

Union Elbow M/F

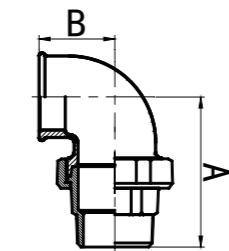

Size	Inch	1/2	3/4	1	1 1/4	1 1/2	
	mm	15	20	25	32	40	
Dim. (mm)	A	76	82	94	107	115	
	B	28	33	38	45	50	
Size	Inch						
	mm						
Dim. (mm)	A						
	B						

### 120

Elbow, 45°

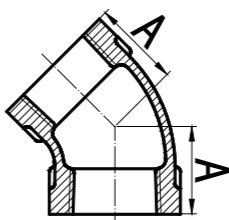

Size	Inch	1/8	1/4	3/8	1/2	3/4	1	1 1/4
	mm	6	8	10	15	20	25	32
Dim. (mm)	A	16	18.5	20	22	25	28	33
	B							
Size	Inch	1 1/2	2	2 1/2	3	4	5	6
	mm	40	50	65	80	100	125	150
Dim. (mm)	A	50	58	69	78	96	77.5	86
	B							

### 121

Street Elbow, 45°

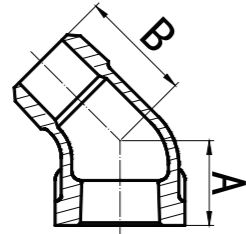

Size	Inch	1/8	1/4	3/8	1/2	3/4	1
	mm	6	8	10	15	20	25
Dim. (mm)	A	16	18.5	20	22	25	28
	B	21	24	25	28	32	37
Size	Inch	1 1/4	1 1/2	2	2 1/2	3	4
	mm	32	40	50	65	80	100
Dim. (mm)	A	33	36	43	49.5	55	66
	B	43	46	55	65	76	94

### 130

Tee

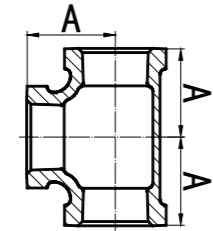

Size	Inch	1/8	1/4	3/8	1/2	3/4	1	1 1/4
	mm	6	8	10	15	20	25	32
Dim. (mm)	A	19	21	25	28	33	38	45
Size	Inch	1 1/2	2	2 1/2	3	4	5	6
	mm	40	50	65	80	100	125	150
Dim. (mm)	A	50	58	69	78	96	115	131

### 130R

Reducing Tee

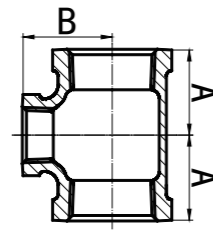

Size	Inch	4X1/2	4X3/4	4X1	4X1 1/4	4X1 1/2
	mm	100X15	100X20	100X25	100X32	100X40
Dim. (mm)	A	50	53	56	60	61
	B	79	79	81	84	84
Size	Inch	1/2X1/8	1/2X1/4	1/2X3/8	3/4X1/4	3/4X3/8
	mm	15X6	15X8	15X10	20X8	20X10
Dim. (mm)	A	22	24	26	26	28
	B	23	24	26	27	28

### 130R

Reducing Tee

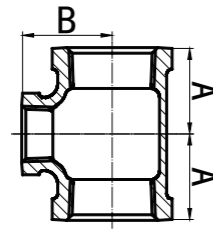

Size	Inch	4X2	4X2 1/2	4X3	3/8X1/4	6X4
	mm	100X50	100X65	100X80	10X8	150X100
Dim. (mm)	A	70	84	82	22	105
	B	86	92	90	22.5	125.5
Size	Inch	3/4X1/2	1X1/4	1X3/8	1X1/2	1X3/4
	mm	20X15	25X8	25X10	25X15	25X20
Dim. (mm)	A	30	28	30	32	35
	B	31	31	32	34	36

### 130R

Reducing Tee

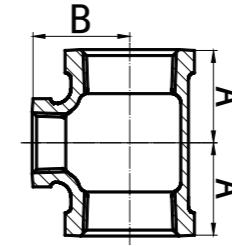

Size	Inch	6X2	6X3	1 1/4X3/4	1 1/4X1	1 1/2X3/8
	mm	150X50	150X80	32X20	32X25	40X10
Dim. (mm)	A	75	92.5	36	40	34
	B	115	120.5	41	42	39
Size	Inch	1 1/4X3/8	1 1/4X1/2	2X1/2	2 1/2X1/2	2 1/2X3/4
	mm	32X10	32X15	50X40	65X15	65X20
Dim. (mm)	A	32	34	52	40	43
	B	36	38	55	56	57

### 130R

Reducing Tee

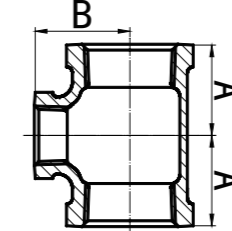

Size	Inch	1 1/2X1/2	1 1/2X3/4	1 1/2X1	1 1/2X1 1/4	2X3/8
	mm	40X15	40X20	40X25	40X32	50X10
Dim. (mm)	A	36	38	42	46	36
	B	42	44	46	48	46
Size	Inch	2 1/2X1	2 1/2X1 1/4	2 1/2X1 1/2	2 1/2X2	3X1/2
	mm	65X25	65X32	65X40	65X50	80X15
Dim. (mm)	A	47	52	55	61	42
	B	60	62	63	66	64

### 130R

Reducing Tee

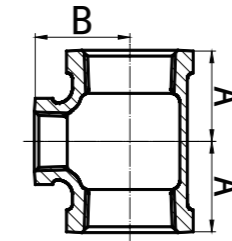

Size	Inch	2X1/2	2X3/4	2X1	2X1 1/4	3X2	3X3/4
	mm	50X15	50X20	50X25	50X32	80X50	80X20
Dim. (mm)	A	38	40	44	48	64	45
	B	48	50	52	54	73	65
Size	Inch	3X1	3X1 1/4	3X1 1/2	3X2 1/2	1/4X1/8	
	mm	80X25	80X32	80X40	80X65	8X6	
Dim. (mm)	A	51	55	58	72	18.5	
	B	67	70	71	76	19	

### 130R

Reducing Tee

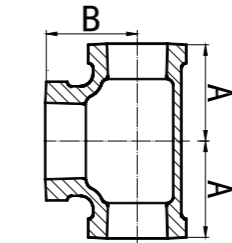

Size	Inch	1/2X1/2X3/4	1/2X1/2X1	3/4X3/4X1	3/4X3/4X1 1/4
	mm	15X15X20	15X15X25	20X20X25	20X20X32
Dim. (mm)	A	31	34	36	41
	B	30	32	35	36
Size	Inch	1X1X2	1X1X2 1/2	1 1/4X1 1/4X1 1/2	1 1/4X1 1/4X2
	mm	25X25X50	25X25X65	32X32X40	32X32X50
Dim. (mm)	A	51	60	48	54
	B	48.5	48	46	48

### 130R

Reducing Tee

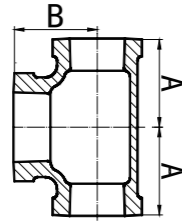

Size	Inch	1/2X1/2X3/4	1/2X1/2X1	3/4X3/4X1	3/4X3/4X1 1/4
	mm	15X15X20	15X15X25	20X20X25	20X20X32
Dim. (mm)	A	31	34	36	41
	B	30	32	35	36
Size	Inch	1X1X2	1X1X2 1/2	1 1/4X1 1/4X1 1/2	1 1/4X1 1/4X2
	mm	25X25X50	25X25X65	32X32X40	32X32X50
Dim. (mm)	A	51	60	48	54
	B	48.5	48	46	48

### 130R

Reducing Tee

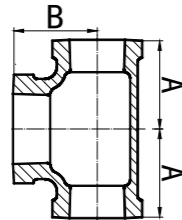

Size	Inch	1X1X1 1/4	1X1X1 1/2	2X2X2 1/2	2 1/2X2 1/2X3
	mm	25X25X32	25X25X40	50X50X65	65X65X80
Dim. (mm)	A	42	46	64	75
	B	40	42	59	72
Size	Inch	1 1/2X1 1/2X2	1 1/2X1 1/2X2 1/2	2 1/2X2 1/2X4	
	mm	40X40X50	40X40X65	65X65X100	
Dim. (mm)	A	55	65	90	
	B	52	55	78	

### 130R

Reducing Tee

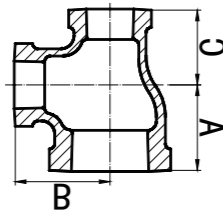

Size	Inch	3/4X1/2X1/2	1X1/2X1/2	1X3/4X3/4
	mm	20X15X15	25X15X15	25X20X20
	Dim. (mm)	A	30	32
Dim. (mm)	B	31	34	36
	C	28	28	33
Size	Inch	1 1/2X3/4X3/4	1 1/2X1X1	1 1/2X1 1/4X1 1/4
	mm	40X20X20	40X25X25	40X32X32
Dim. (mm)	A	38	42	46
	B	43	46	48
	C	32	38	45

### 130R

Reducing Tee

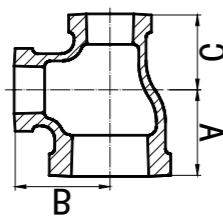

Size	Inch	1 1/4X1/2X1/2	1 1/4X3/4X3/4	1 1/4X1X1	2X1X1
	mm	32X15X15	32X20X20	32X25X25	50X25X25
	Dim. (mm)	A	34	36	40
Dim. (mm)	B	38	41	42	51
	C	27	33	38	38
Size	Inch	2X1 1/4X1 1/4	2X1 1/2X1 1/2	2 1/2X2X2	3X2X2
	mm	50X32X32	50X40X40	65X50X50	80X50X50
Dim. (mm)	A	48	52	60.5	64
	B	54	55	66	73
	C	45	50	57	57

### 130R

Reducing Tee

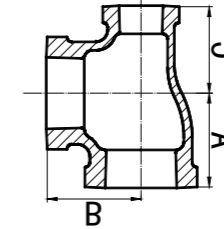

Size	Inch	3/4X1/2X3/4	1X1/4X1	1X1/2X1	1 1/4X1 1/4X1 1/4	1 1/2X1 1/2X1 1/2
	mm	20X8X20	25X8X25	25X15X25	32X25X32	40X15X40
Dim. (mm)	A	33	38	38	45	50
	B	33	38	38	45	50
	C	31	30	34	42	42
Size	Inch	1 1/2X3/4X1 1/2	1X3/4X1	1 1/4X1 1/2X1 1/4	1 1/4X3/4X1 1/4	1 1/2X1 1/2X1 1/2
	mm	40X20X40	25X20X25	32X15X32	32X20X32	40X25X40
Dim. (mm)	A	50	38	45	45	50
	B	50	38	45	45	50
	C	44	36	38	41	46

### 130R

Reducing Tee

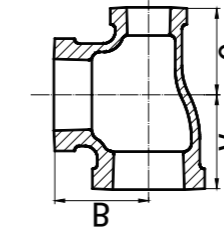

Size	Inch	1 1/2X1 1/4X1 1/2	2X1/2X2	2X3/4X2	2X1X2
	mm	40X32X40	50X15X50	50X20X50	50X25X50
Dim. (mm)	A	50	57	58	58
	B	50	57	58	58
	C	48	47.5	50	52
Size	Inch	2X1 1/4X2	2X1 1/2X2	2 1/2X1 1/2X2 1/2	2 1/2X2X2 1/2
	mm	50X32X50	50X40X50	65X40X65	65X50X65
Dim. (mm)	A	58	58	68.5	67
	B	58	58	68.5	67
	C	54	55	63.5	65

### 130R

Reducing Tee

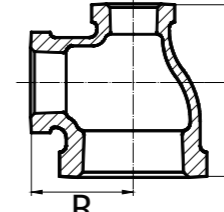

Size	Inch	4X3X2	3/4X1/2X1	1X1/2X3/4	1 1/4X3/4X1
	mm	100X80X50	20X15X25	25X15X20	32X20X25
	Dim. (mm)	A	67	38	35
Dim. (mm)	B	83.5	34	36	42
	C	60	33	31	36
Size	Inch	1 1/4X1 1/2	1 1/4X1 3/4	1 1/4X1 1/2X3/4	1 1/4X1 1/2X1 1/4
	mm	32X25X15	32X25X20	32X15X20	32X15X25
Dim. (mm)	A	34	36	35	39
	B	38	41	38	41.5
	C	32	35	29	34

### 130R

Reducing Tee

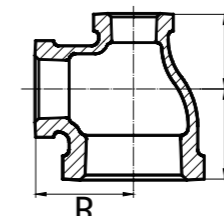

Size	Inch	1 1/4X3/4X1/2	1 1/2X1/2X1	1 1/2X3/4X1	1 1/2X3/4X1 1/4
	mm	32X20X15	40X15X25	40X20X25	40X20X32
	Dim. (mm)	A	40	44	44
Dim. (mm)	B	42.5	46	46	48
	C	37	34	35	41
Size	Inch	1 1/2X1 1/2	1 1/2X3/4X1 1/4	1 1/2X1 1/4X1/2	2X1X1 1/2
	mm	40X25X15	40X32X32	40X32X15	50X25X40
Dim. (mm)	A	37	45	36	51
	B	41	47	42	55
	C	32	41.5	34	45.5

### 130R

Reducing Tee

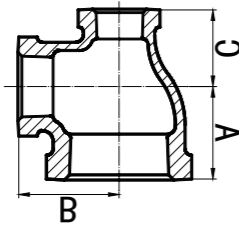

Size	Inch	2X11/4X1	2X11/4X1/2	11/2X11/4X3/4	11/2X11/4X1
	mm	50X32X25	50X32X40	40X32X20	40X32X25
Dim. (mm)	A	40	52	38	42
	B	51	55	44	46
	C	44	48	36	40
Size	Inch	11/2X11/4X2	2X11/2X1/2	2X11/2X3/4	2X11/2X1
	mm	40X32X50	50X40X15	50X40X20	50X40X25
Dim. (mm)	A	55	38	40	44
	B	51.5	48	50	52
	C	53.5	36	39	42

### 130R

Reducing Tee

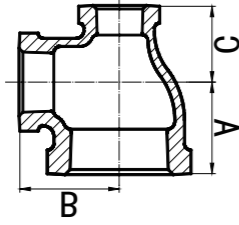

Size	Inch	2X11/2X11/4	21/2X2X1/2	21/2X2X1
	mm	50X40X32	65X50X15	65X50X25
Dim. (mm)	A	48	57	53
	B	54	64	60
	C	46	52	53
Size	Inch	21/2X2X11/4	3X21/2X2	
	mm	65X50X32	80X65X50	
Dim. (mm)	A	57	67	
	B	64	74.5	
	C	52	64	

### 131

Pitcher Tee

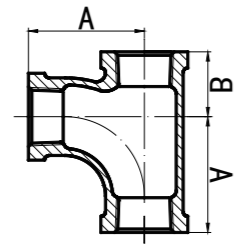

Size	Inch	1/2	3/4	1	11/4	11/2	2
	mm	15	20	25	32	40	50
Dim. (mm)	A	45	50	63	76	85	102
	B	24	28	33	40	43	53
Size	Inch						
	mm						
Dim. (mm)	A						
	B						

### 131R

Reducing Pitcher Tee

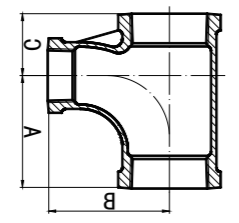

Size	Inch	3/4X1/2	1X1/2	1X3/4	1X3/4X3/4
	mm	20X15	25X15	25X20	25X20X20
Dim. (mm)	A	47	49	53	53
	B	48	51	54	54
	C	25	28	30	28
Size	Inch	11/4X1/2	11/4X3/4	11/2X3/4	11/2X1
	mm	32X15	32X20	40X20	40X25
Dim. (mm)	A	51	55	55	66
	B	56	58	61	71
	C	30	33	33	36

### 134

Service Tee

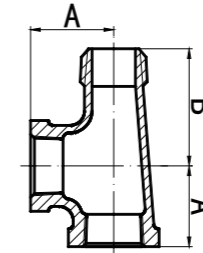

Size	Inch	1/2	3/4	1	11/4	11/2	2
	mm	15	20	25	32	40	50
Dim. (mm)	A	28.5	33.5	38	44.5	49.5	57
	B	41.5	48	54.5	62	68.5	83
Size	Inch						
	mm						
Dim. (mm)	A						
	B						

### 134R

Reducing Service Tee

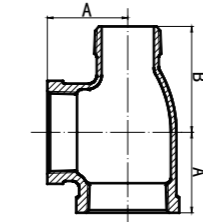

Size	Inch	2X11/4	21/2X2	3X21/2			
	mm	50X40	65X50	80X65			
Dim. (mm)	A	57	69	78			
	B	75	88	106			
Size	Inch						
	mm						
Dim. (mm)	A						
	B						

### 165

Lateral Y Branche, 45°

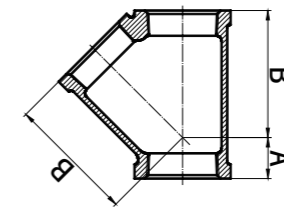

Size	Inch	1/2	3/4	1	11/4	11/2	2
	mm	15	20	25	32	40	50
Dim. (mm)	A	15.5	18.3	21.6	26	27.9	31.5
	B	43.4	52	61.7	74.2	83.3	99.8
Size	Inch	21/2	3	4			
	mm	65	80	100			
Dim. (mm)	A	38.6	43.4	51			
	B	120	141	177			

### 180

Cross

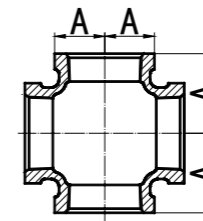

Size	Inch	1/8	1/4	3/8	1/2	3/4	1
	mm	6	8	10	15	20	25
Dim. (mm)	A	19	21	25	28	33	38
	B						
Size	Inch	11/4	11/2	2	21/2	3	4
	mm	32	40	50	65	80	100
Dim. (mm)	A	45	50	58	69	78	96
	B						

### 180R

Reducing Cross

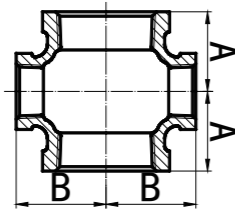

Size	Inch	4X1	4X1 1/4	4X1 1/2	4X2	4X2 1/2
	mm	100X25	100X32	100X40	100X50	100X65
Dim. (mm)	A	56	60	61	70	84
	B	81	84	84	86	92
Size	Inch	1 1/2 X 1/2	1 1/2 X 3/4	1 1/2 X 1	1 1/2 X 1 1/4	2 X 3/4
	mm	40X15	40X20	40X25	40X32	50X20
Dim. (mm)	A	36	38	42	46	40
	B	42	44	46	48	50

### 180R

Reducing Cross

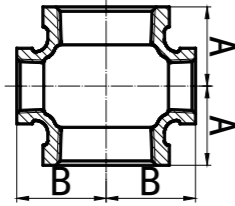

Size	Inch	4X3	3/4 X 1/2	1 X 1/2	1 X 3/4	1 1/4 X 1/2
	mm	100X80	20X15	25X15	25X20	32X15
Dim. (mm)	A	82	30	32	35	34
	B	90	31	34	36	38
Size	Inch	2 X 1	2 X 1 1/4	2 X 1 1/2	2 1/2 X 3/4	2 1/2 X 1
	mm	50X25	50X32	50X40	65X20	65X25
Dim. (mm)	A	44	48	52	43	47
	B	52	54	55	57	60

### 180R

Reducing Cross

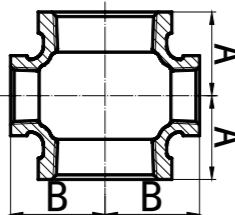

Size	Inch	1 1/4 X 3/4	1 1/4 X 1	2 1/2 X 2	3 X 3/4	3 X 1	2 1/2 X 1 1/4
	mm	32X20	32X25	65X50	80X20	80X25	65X32
Dim. (mm)	A	36	40	61	45	51	52
	B	41	42	66	65	67	62
Size	Inch	2 1/2 X 1 1/2	3 X 1 1/4	3 X 1 1/2	3 X 2	3 X 2 1/2	
	mm	65X40	80X32	80X40	80X50	80X65	
Dim. (mm)	A	55	55	58	64	72	
	B	63	70	71	73	76	

### 220

Socket

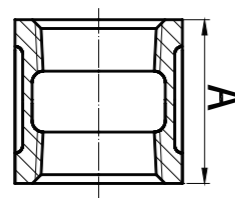

Size	Inch	1/8	1/4	3/8	1/2	3/4	1	1 1/4
	mm	6	8	10	15	20	25	32
Dim. (mm)	A	25	27	30	36	39	45	50
Size	Inch	1 1/2	2	2 1/2	3	4	5	6
	mm	40	50	65	80	100	125	150
Dim. (mm)	A	55	65	74	80	94	95	105

### 220S

Socket R/L

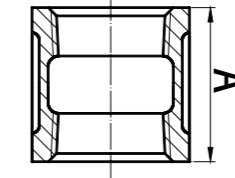

Size	Inch	1/2	3/4	1	1 1/4	1 1/2	2
	mm	15	20	25	32	40	50
Dim. (mm)	A	36	39	45	50	55	65
Size	Inch						
	mm						
Dim. (mm)	A						

### 240

Reducing Socket

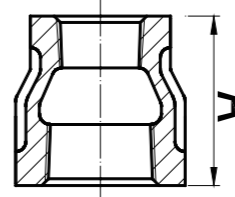

Size	Inch	4X1	4X1 1/4	4X1 1/2	4X2	4X2 1/2
	mm	100X25	100X32	100X40	100X50	100X65
Dim. (mm)	A	94	94	94	94	94
Size	Inch	1/2 X 1/8	1/2 X 1/4	1/2 X 3/8	3/4 X 1/8	3/4 X 1/4
	mm	15X6	15X8	15X10	20X6	20X8
Dim. (mm)	A	36	36	36	39	39

### 240

Reducing Socket

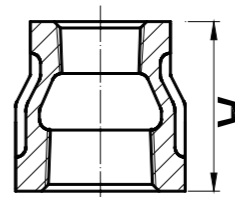

Size	Inch	4X3	3/8 X 1/8	3/8 X 1/4	5X4	6X4
	mm	100X80	10X6	10X8	125X100	150X100
Dim. (mm)	A	94	30	30	122	105
Size	Inch	3/4 X 3/8	3/4 X 1/2	1 X 1/4	1 X 3/8	1 X 1/2
	mm	20X10	20X15	25X8	25X10	25X15
Dim. (mm)	A	39	39	45	45	45

### 240

Reducing Socket

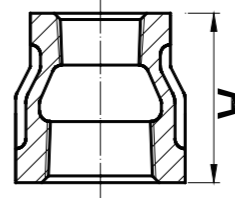

Size	Inch	6X2	6X3	1 1/4 X 3/8	1 1/4 X 1/2	1 1/4 X 3/4
	mm	150X50	150X80	32X10	32X15	32X20
Dim. (mm)	A	105	105	50	50	50
Size	Inch	1 X 3/4	1 1/4 X 1/4	2 X 1	2 X 1 1/4	2 X 1 1/2
	mm	25X20	32X8	50X25	50X32	50X40
Dim. (mm)	A	45	50	65	65	74

### 240 Reducing Socket

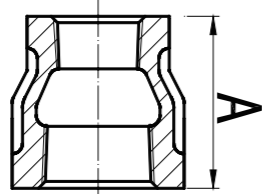
Size	Inch	6X2	6X3	11/4X3/8	11/4X1/2	11/4X3/4	1X3/4
	mm	150X50	150X80	32X10	32X15	32X20	25X20
Dim. (mm)	A	105	105	50	50	50	45
Size	Inch	11/4X1/4	2X1	2X11/4	2X11/2	11/4X1	11/2X1/4
	mm	32X8	50X25	50X32	50X40	32X25	40X8
Dim. (mm)	A	50	65	65	74	50	55

### 240 Reducing Socket

Size	Inch	11/2X3/8	11/2X1/2	11/2X3/4	21/2X1/2	21/2X3/4	21/2X1
	mm	40X10	40X15	40X20	65X15	65X20	65X25
Dim. (mm)	A	55	55	55	74	74	74
Size	Inch	21/2X11/4	21/2X11/2	11/2X1	11/2X11/4	2X1/2	2X3/4
	mm	65X32	65X40	40X25	40X32	50X15	50X20
Dim. (mm)	A	74	74	55	55	65	65

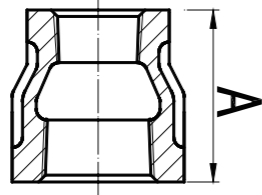
### 240 Reducing Socket

Size	Inch	3X11/4	21/2X2	3X1/2	3X3/4	3X1	3X11/2
	mm	80X32	65X50	80X15	80X20	80X25	80X40
Dim. (mm)	A	80	74	80	80	80	80
Size	Inch	3X2	3X21/2	1/4X1/8			
	mm	80X50	80X65	8X6			
Dim. (mm)	A	80	80	27			

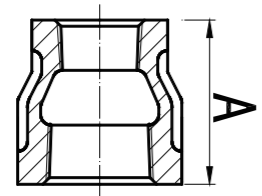
### 241 Bushing

Size	Inch	4X3/4	4X1	4X11/4	4X11/2	4X3
	mm	100X20	100X25	100X32	100X40	100X80
Dim. (mm)	A	51	51	51	51	51
Size	Inch	1/2X3/8	3/4X1/8	3/4X1/4	3/4X3/8	3/4X1/2
	mm	15X10	20X6	20X8	20X10	20X15
Dim. (mm)	A	24	26	26	26	26

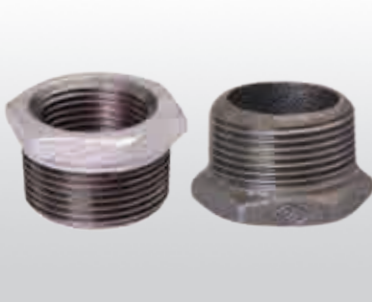
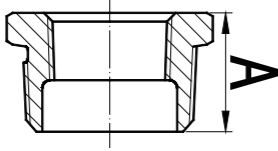
### 241 Bushing

Size	Inch	3/8X1/8	3/8X1/4	5X4	6X5	6X21/2
	mm	10X6	10X8	125X100	150X125	150X65
Dim. (mm)	A	20	20	47	69	69
Size	Inch	1X1/4	1X3/8	1X1/2	1X3/4	11/4X3/8
	mm	25X8	25X10	25X15	25X20	32X10
Dim. (mm)	A	29	29	29	29	31

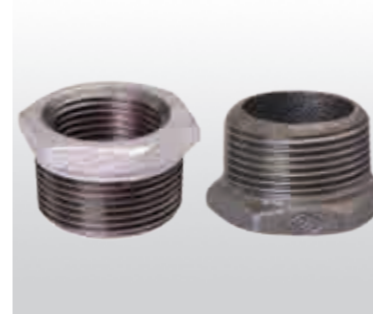
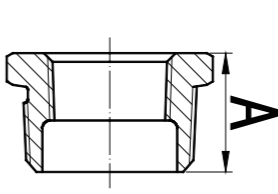
### 241 Bushing

Size	Inch	1/2X1/8	1/2X1/4	11/4X1	11/2X1/4	11/2X3/8
	mm	15X6	15X8	32X25	40X8	40X10
Dim. (mm)	A	24	24	31	31	31
Size	Inch	11/4X1/2	11/4X3/4	21/2X11/2	21/2X2	3X2
	mm	32X15	32X20	65X40	65X50	80X50
Dim. (mm)	A	31	31	40	40	44

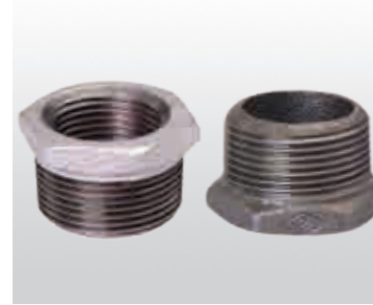
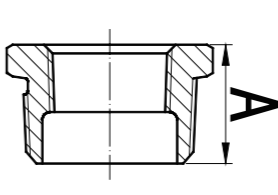
### 241 Bushing

Size	Inch	11/2X1/2	11/2X3/4	11/2X1	11/2X11/4	2X1	3X21/2
	mm	40X15	40X20	40X25	40X32	50X25	80X65
Dim. (mm)	A	31	31	31	31	35	44
Size	Inch	1/4X1/8	2X11/4	2X11/2	21/2X1/2	21/2X3/4	
	mm	8X6	50X32	50X40	65X15	65X20	
Dim. (mm)	A	20	35	35	40	40	

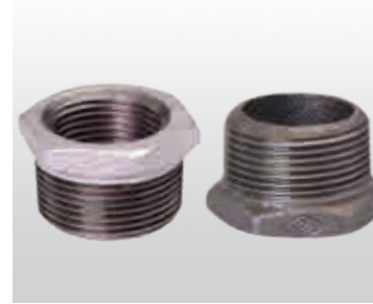
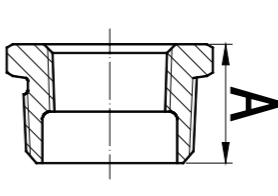
### 241D Bushing

Size	Inch	2X1/2	2X3/4	21/2X1	21/2X11/4	3X1/2
	mm	50X15	50X20	65X25	65X32	80X15
Dim. (mm)	A	35	35	40	40	44
	B	48	48	54	54	59
Size	Inch	6X4	3X3/4	3X1	3X11/4	3X11/2
	mm	150X100	80X20	80X25	80X32	80X40
Dim. (mm)	A	63	44	44	44	44
	B	86	59	59	59	59

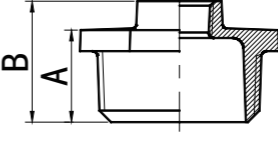
### 241D

Bushing

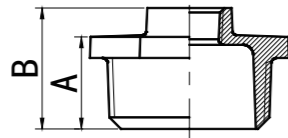

Size	Inch	4X2	4X2 1/2	6X3		
	mm	100X50	100X65	150X80		
Dim. (mm)	A	51	51	63		
	B	69	69	86		
Size	Inch					
	mm					
Dim. (mm)	A					
	B					

### 245

Reducing Hexagon Nipple

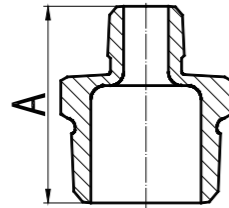

Size	Inch	4X2	4X2 1/2	4X3	3/8X1/4	1/2X1/4
	mm	100X50	100X65	100X80	10X8	15X8
Dim. (mm)	A	87	87	87	38	44
Size	Inch	1 1/4X3/4	1 1/4X1	1 1/2X1/2	1 1/2X3/4	1 1/2X1
	mm	32X20	32X25	40X15	40X20	40X25
Dim. (mm)	A	57	57	59	59	59

### 245

Reducing Hexagon Nipple

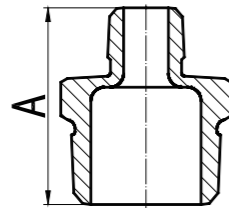

Size	Inch	1/2X3/8	3/4X1/4	3/4X3/8	3/4X1/2	1X1/2
	mm	15X10	20X8	20X10	20X15	25X15
Dim. (mm)	A	44	47	47	47	53
Size	Inch	1 1/2X1 1/4	2X1/2	2X3/4	2X1	2X1 1/4
	mm	40X32	50X15	50X20	50X25	50X32
Dim. (mm)	A	59	68	68	68	68

### 245

Reducing Hexagon Nipple

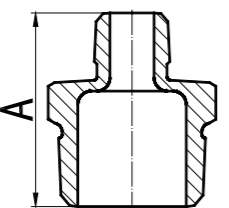

Size	Inch	1X3/4	1 1/4X1/2	2 1/2X1 1/4	2 1/2X1 1/2	2 1/2X2	2X1 1/2
	mm	25X20	32X15	65X32	65X40	65X50	50X40
Dim. (mm)	A	53	57	75	75	75	68
Size	Inch	1/4X1/8	2 1/2X1	3X1 1/2	3X2	3X2 1/2	
	mm	8X6	65X25	80X40	80X50	80X65	
Dim. (mm)	A	31	75	83	83	83	

### 246

Reducing Socket M/F

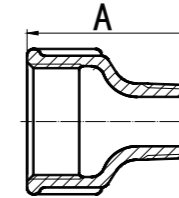

Size	Inch	3/8X1/4	1/2X1/4	1/2X3/8	3/4X3/8	3/4X1/2
	mm	10X8	15X8	15X10	20X10	20X15
Dim. (mm)	A	35	43	43	48	48
Size	Inch	1 1/2X1 1/4	2X1	2X1 1/4	2X1 1/2	1X1/2
	mm	40X32	50X25	50X32	50X40	25X15
Dim. (mm)	A	63	70	70	70	55

### 246

Reducing Socket M/F

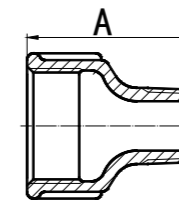

Size	Inch	1X3/4	1 1/4X1/2	1 1/4X3/4	1 1/4X1	1 1/2X3/4
	mm	25X20	32X15	32X20	32X25	40X20
Dim. (mm)	A	55	60	60	60	63
Size	Inch	1 1/2X1				
	mm	40X25				
Dim. (mm)	A	63				

### 270

Parallel Thread Socket

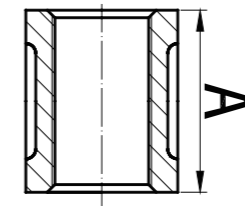

Size	Inch	1/8	1/4	3/8	1/2	3/4	1	1 1/4
	mm	6	8	10	15	20	25	32
Dim. (mm)	A	25	27	30	36	39	45	50
Size	Inch	6	1 1/2	2	2 1/2	3	4	
	mm	150	40	50	65	80	100	
Dim. (mm)	A	120	55	65	74	80	94	

### 280

Hexagon Nipple

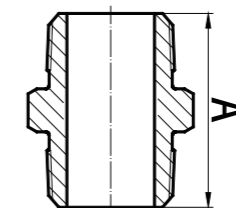

Size	Inch	1/8	1/4	3/8	1/2	3/4	1	1 1/4
	mm	6	8	10	15	20	25	32
Dim. (mm)	A	29	36	38	44	47	53	57
Size	Inch	5	6	1 1/2	2	2 1/2	3	4
	mm	125	150	40	50	65	80	100
Dim. (mm)	A	103	110	59	68	75	83	95



### 291

Plain Plug

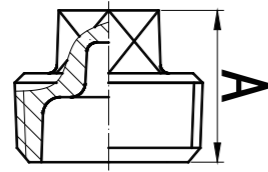

Size	Inch	1/8	1/4	3/8	1/2	3/4	1	1 1/4
	mm	6	8	10	15	20	25	32
Dim. (mm)	A Min	11	14	15	18	20	23	29
Size	Inch	1 1/2	2	2 1/2	3	4	6	
	mm	40	50	65	80	100	150	
Dim. (mm)	A Min	30	36	39	44	58	71.5	

### 291LM

Plain Plug

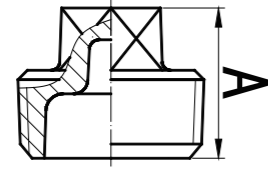

Size	Inch	1/2	3/4	1	1 1/4	1 1/2	2
	mm	15	20	25	32	40	50
Dim. (mm)	A	25	28.5	32.5	35.1	37.6	40.1
Size	Inch	2 1/2	3	4			
	mm	65	80	100			
Dim. (mm)	A	46	50	64.5			

### 291N

Countersunk Plug

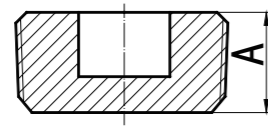

Size	Inch	1/2	3/4	1	1 1/4	1 1/2	2
	mm	15	20	25	32	40	50
Dim. (mm)	A Min	14.2	16	19	20.3	21.1	22.4
Size	Inch	2 1/2	3				
	mm	65	80				
Dim. (mm)	A Min	27.2	38.7				

### 291S

Solid Plug

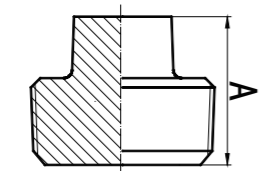
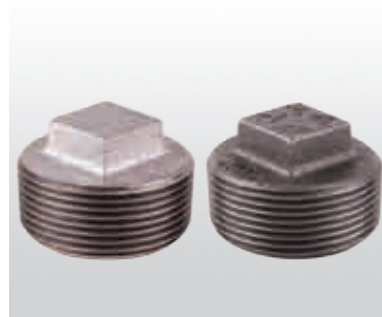

Size	Inch	1/4	3/8	1/2	3/4	1	1 1/4
	mm	8	10	15	20	25	32
Dim. (mm)	A Min	14	15	18	20	23	29
Size	Inch	1 1/2	2	2 1/2	3		
	mm	40	50	65	80		
Dim. (mm)	A Min	30	36	39	44		

### 300

Cap

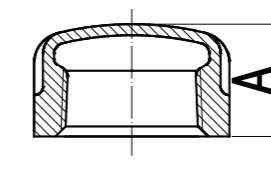
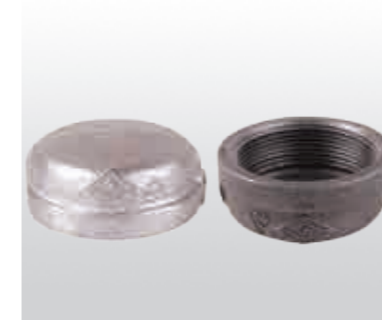

Size	Inch	1/8	1/4	3/8	1/2	3/4	1	1 1/4
	mm	6	8	10	15	20	25	32
Dim. (mm)	A Min	13	15	17	19	22	24	27
Size	Inch	1 1/2	2	2 1/2	3	4	5	6
	mm	40	50	65	80	100	125	150
Dim. (mm)	A Min	27	32	35	38	45	54	61

### 310

Locknut

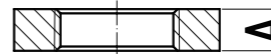
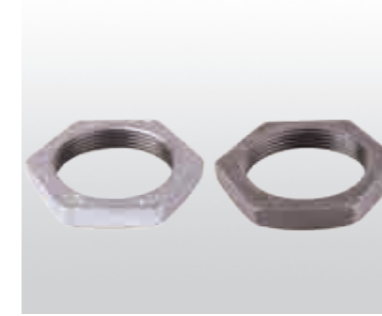

Size	Inch	1/4	3/8	1/2	3/4	1	1 1/4
	mm	8	10	15	20	25	32
Dim. (mm)	A	6	7	8	9	10	11
Size	Inch	1 1/2	2	2 1/2	3	4	
	mm	40	50	65	80	100	
Dim. (mm)	A	12	13	16	19	23	

### 312

Backnut

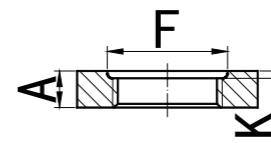

Size	Inch	1/2	3/4	1	1 1/4	1 1/2	2	4
	mm	15	20	25	32	40	50	100
Dim. (mm)	A Min	7.9	8.6	9.7	10.7	11.9	13.5	20.3
	F Min	24.6	31.2	38.1	47.2	53.9	66.8	127
	K	1.5	1.5	1.5	1.5	1.5	2.3	3.3

### 321-4

Flange Bs4504

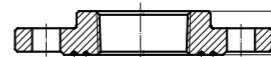

Size	Inch	1 1/4	1 1/2	2	2 1/2	3	4
	mm	32	40	50	65	80	100
Dim. (mm)	A	23	23	28	35	38	38
Size	Inch	6					
	mm	150					
Dim. (mm)	A	46					

### 321-6

Flange 1600/4

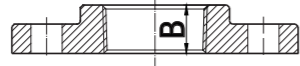

Size	Inch	1 1/4	1 1/2	2	2 1/2	3	4
	mm	32	40	50	65	80	100
Dim. (mm)	B	20	20	22	26	28	34
Size	Inch	6					
	mm	150					
Dim. (mm)	B	40					

### 321-H

Flange

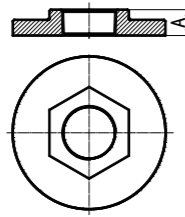
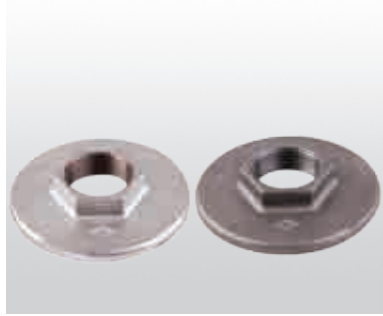

Size	Inch	1/2	3/4	1	1 1/4	1 1/2	2
	mm	15	20	25	32	40	50
Dim. (mm)	A	15	16	19	21	21	26
Size	Inch	2 1/2	3	4			
	mm	65	80	100			
Dim. (mm)	A	30	33	39			

### 321P

Flange

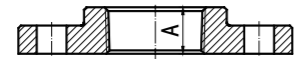

Size	Inch	1/2	3/4	1	1 1/4	1 1/2	2
	mm	15	20	25	32	40	50
Dim. (mm)	A	15	16	19	21	21	26
Size	Inch	2 1/2	3	4	5	6	
	mm	65	80	100	125	150	
Dim. (mm)	A	30	33	39	40	40	

### 321PW

Flange

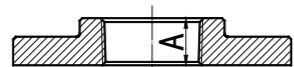

Size	Inch	1/2	3/4	1	1 1/4	1 1/2	2
	mm	15	20	25	32	40	50
Dim. (mm)	A	15	16	19	21	21	26
Size	Inch	2 1/2	3	4	5	6	
	mm	65	80	100	125	150	
Dim. (mm)	A	30	33	39	40	40	

### 321TD

Flange

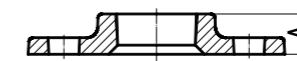
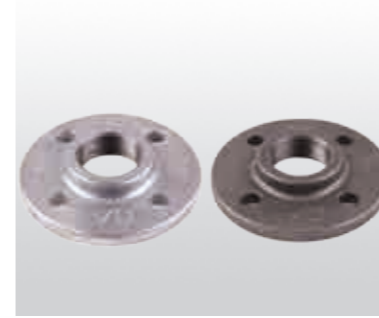

Size	Inch	1	1 1/4	1 1/2	2	2 1/2	3
	mm	25	32	40	50	65	80
Dim. (mm)	A	16	17.4	23	25	25	26.8
Size	Inch	4	6				
	mm	100	150				
Dim. (mm)	A	31.5	35				

### 330

Flat Seat Union

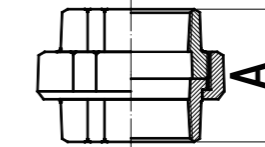
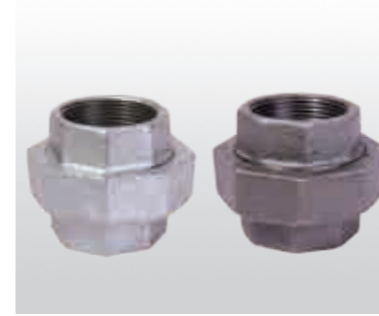

Size	Inch	1/8	1/4	3/8	1/2	3/4	1	1 1/4
	mm	6	8	10	15	20	25	32
Dim. (mm)	A	38	42	45	48	52	58	65
Size	Inch	1 1/2	2	2 1/2	3	4	6	
	mm	40	50	65	80	100	150	
Dim. (mm)	A	70	78	85	95	100	144	

### 330D

Flat Seat Union

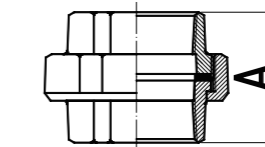

Size	Inch	1/8	1/4	3/8	1/2	3/4	1	1 1/4
	mm	6	8	10	15	20	25	32
Dim. (mm)	A	38	42	45	48	52	58	65
Size	Inch	1 1/2	2	2 1/2	3	4	6	
	mm	40	50	65	80	100	150	
Dim. (mm)	A	70	78	85	95	100	144	

### 331

Flat Seat Union M/F

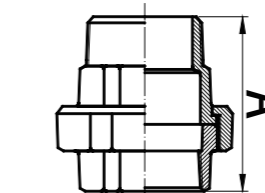

Size	Inch	1/2	3/4	1	1 1/4	1 1/2	2
	mm	15	20	25	32	40	50
Dim. (mm)	A	66	72	80	90	95	106
Size	Inch	2 1/2	3	4			
	mm	65	80	100			
Dim. (mm)	A	118	130	133			

### 340

Conical Joint Union

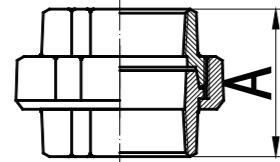

Size	Inch	1/8	1/4	3/8	1/2	3/4	1
	mm	6	8	10	15	20	25
Dim. (mm)	A	38	42	45	48	52	58
Size	Inch	1 1/4	1 1/2	2	2 1/2	3	4
	mm	32	40	50	65	80	100
Dim. (mm)	A	65	70	78	85	95	110

### 340Q

Deflection Union

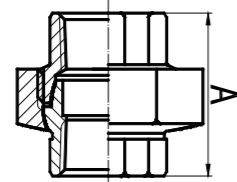
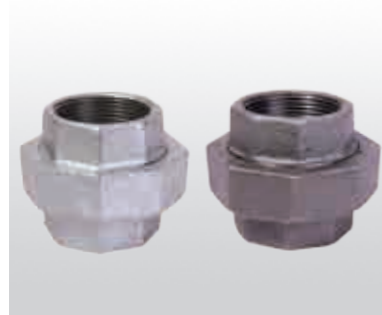

Size	Inch	1/2	3/4	1	1 1/4	1 1/2	2
	mm	15	20	25	32	40	50
Dim. (mm)	A	46	49	55	64	74.5	83
Size	Inch						
	mm						
Dim. (mm)	A						

### 341

Conical Joint Union M/F

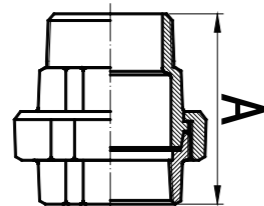

Size	Inch	1/4	3/8	1/2	3/4	1	1 1/4
	mm	8	10	15	20	25	32
Dim. (mm)	A	55	55	66	72	80	90
Size	Inch	1 1/2	2	2 1/2	3	4	
	mm	40	50	65	80	100	
Dim. (mm)	A	95	106	118	130	133	

### 342

Conical Joint Union

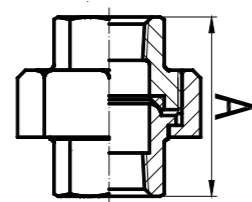
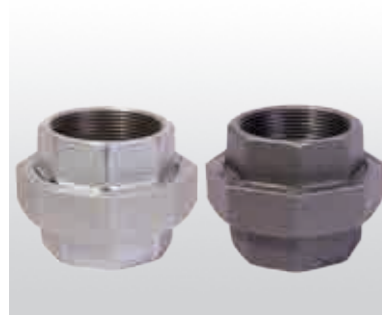

Size	Inch	1/8	1/4	3/8	1/2	3/4	1	1 1/4
	mm	6	8	10	15	20	25	32
Dim. (mm)	A Min	32	36.5	41	43.5	49.5	52.5	57.5
Size	Inch	1 1/2	2	2 1/2	3	4	6	
	mm	40	50	65	80	100	150	
Dim. (mm)	A Min	61	70	82	89	98	147	

### 342A

Double Bronze Navy Union

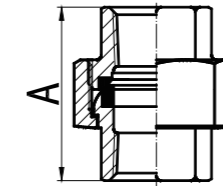

Size	Inch	1/2	3/4	1	1 1/4	1 1/2	2
	mm	15	20	25	32	40	50
Dim. (mm)	A	48	52	58	65	70	78
Size	Inch						
	mm						
Dim. (mm)	A						

### 526

Long Adapter M/F

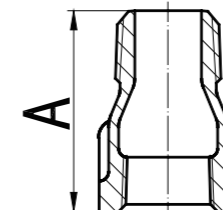

Size	Inch	1/2X30	1/2X40	1/2X50	1/2X60	1/2X100
	mm	15X30	15X40	15X50	15X60	15X100
Dim. (mm)	A	30	40	50	60	100
Size	Inch	1/2X30	1/2X40	1/2X50	1/2X60	1/2X100
	mm	15X30	15X40	15X50	15X60	15X100
Dim. (mm)	A	30	40	50	60	100

### 529A

Long Extension Piece

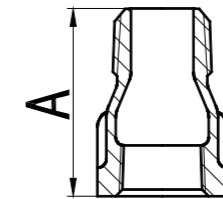

Size	Inch	1/4	3/8	1/2	3/4	1	1 1/4
	mm	8	10	15	20	25	32
Dim. (mm)	A	33	35	43	48	55	60
Size	Inch	1 1/2	2	2 1/2	3	4	
	mm	40	50	65	80	100	
Dim. (mm)	A	61.5	68	76	83	97	

### 529X

Short Extension Piece

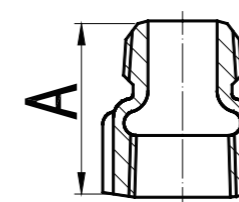

Size	Inch	1/2				
	mm	15				
Dim. (mm)	A	32				
Size	Inch					
	mm					
Dim. (mm)	A					

### 1221

Side Outlet Elbow

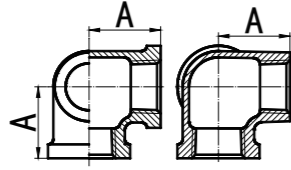

Size	Inch	1/2	3/4	1	1 1/2	2	
	mm	15	20	25	40	50	
Dim. (mm)	A	28	33	38	50	58	
Size	Inch						
	mm						
Dim. (mm)	A						

### 1223

Side Outlet Tee

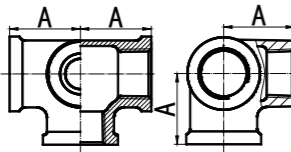

Size	Inch	1/2	3/4	1	1 1/4		
	mm	15	20	25	32		
Dim. (mm)	A	28	33	38	45		
Size	Inch						
	mm						
Dim. (mm)	A						

### 1224

Side Outlet Cross

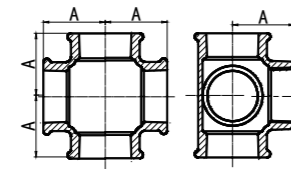

Size	Inch	1 1/4	1 1/2				
	mm	32	40				
Dim. (mm)	A	45	50				
Size	Inch						
	mm						
Dim. (mm)	A						

### LAA

Coupling Luck F/F

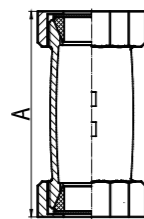

Size	Inch	1/2	3/4	1	1 1/4	1 1/2	2
	mm	15	20	25	32	40	50
Dim. (mm)	A	95	104	110	114	122	129
Size	Inch						
	mm						
Dim. (mm)	A						

### LAF

Coupling Luck M/F

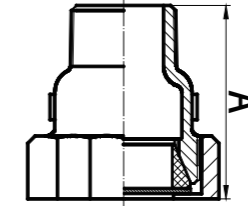

Size	Inch	1/2	3/4	1	1 1/4	1 1/2	2
	mm	15	20	25	32	40	50
Dim. (mm)	A	59	63	65	69	71	79
Size	Inch						
	mm						
Dim. (mm)	A						

### LCC

Long Compression Coupling

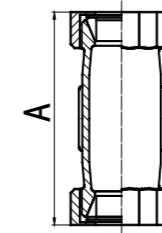

Size	Inch	1/2	3/4	1	1 1/4	1 1/2	2
	mm	15	20	25	32	40	50
Dim. (mm)	A	93	101	109	114	118	121
Size	Inch	2 1/2	3	4			
	mm	65	80	100			
Dim. (mm)	A	137	145	155			

### SCC

Short Compression Coupling

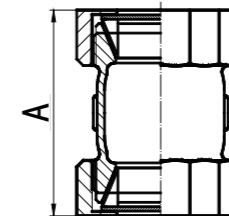

Size	Inch	1/2	3/4	1	1 1/4	1 1/2	2
	mm	15	20	25	32	40	50
Dim. (mm)	A	62	69	73	79	79	84
Size	Inch	2 1/2	3				
	mm	65	80				
Dim. (mm)	A	100	110				

### TCC

Compression Tee

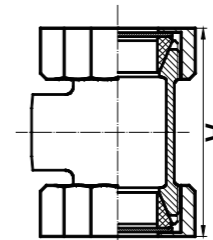

Size	Inch	1/2	3/4				
	mm	15	20				
Dim. (mm)	A	80	88				
Size	Inch						
	mm						
Dim. (mm)	A						

# Malleable Iron Collar Fittings

## BS Standard



### 90 Elbow, 90°

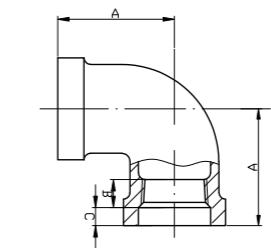

Size/规格	Inch	1/2	3/4	1	1 1/4	1 1/2	2
	mm	15	20	25	32	40	50
Dim./尺寸 (mm)	A	35.5	41	47	55	60	69
	B	11	13	15	17	18	20
	C	7	8	9	10	10	11
Size/规格	Inch	3	4	6			
	mm	80	100	150			
Dim./尺寸 (mm)	A	91	110	145			
	B	25.5	28.5	33			
	C	13	14	15			

### 90R Reducing Elbow, 90°

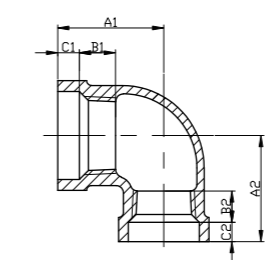

Size/规格	Inch	3/4X1/2	1X3/4	1 1/4X1	
	mm	20X15	25X20	32X25	
Dim./尺寸 (mm)	A1	38	44	50	
	B1	13	15	17	
	C1	8	9	10	
	A2	38	44	51	
	B2	11	13	15	
	C2	7	8	9	

### 92 Street Elbow, 90°

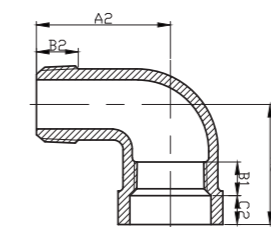

Size/规格	Inch	1/2	3/4	1	1 1/4	1 1/2	2
	mm	15	20	25	32	40	50
Dim./尺寸 (mm)	A1	35	41	47	55	60	69
	B1	11	13	15	17	18	20
	C1	7	8	9	10	10	11
	A2	41	48	54	62	68	82.5
	B2	14	15	18	19	20	22

### 120 Elbow, 45°

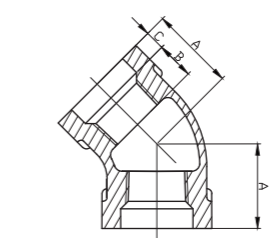

Size/规格	Inch	1/2	3/4	1	1 1/4	1 1/2	2
	mm	15	20	25	32	40	50
Dim./尺寸 (mm)	A	28	33	38	44	46	53
	B	11	13	15	17	18	20
	C	7	8	9	10	10	11
Size/规格	Inch	3	4	6			
	mm	80	100	150			
Dim./尺寸 (mm)	A	67	79	97			
	B	25.5	28.5	33			
	C	13	14	15			

### 130

Tee

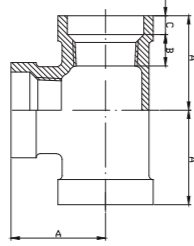

Size/规格	Inch	1/2	3/4	1	1 1/4	1 1/2	2
	mm	15	20	25	32	40	50
Dim./尺寸 (mm)	A	35.5	41	47	55	60	69
	B	11	13	15	17	18	20
	C	7	8	9	10	10	11
Size/规格	Inch	3	4	6			
	mm	80	100	150			
Dim./尺寸 (mm)	A	91	110	145			
	B	25.5	28.5	33			
	C	13	14	15			

### 130R

Reducing Tee

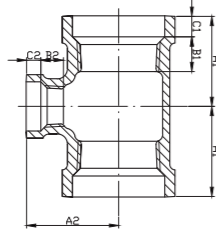

Size/规格	Inch	3/4X1/2	1X1/2	1X3/4	1 1/4X1/2	1 1/4X3/4
	mm	20X15	25X15	25X20	32X15	32X20
Dim./尺寸 (mm)	A1	38	41	43.5	44	46
	B1	13	15	15	17	17
	C1	8	9	9	10	10
	A2	38	41	44.5	45	49
	B2	11	11	13	11	13
	C2	7	7	8	7	8

### 130R

Reducing Tee

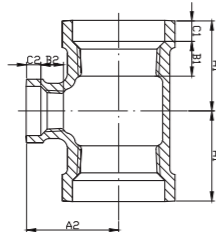

Size/规格	Inch	1 1/4X1	1 1/2X1/2	1 1/2X3/4	1 1/2X1	1 1/2X1 1/4
	mm	32X25	40X15	40X20	40X25	40X32
Dim./尺寸 (mm)	A1	50	46	48.5	52	56
	B1	17	18	18	18	18
	C1	10	10	10	10	10
	A2	51	49	52.5	54.5	57.5
	B2	15	11	13	15	17
	C2	9	7	8	9	10

### 130R

Reducing Tee

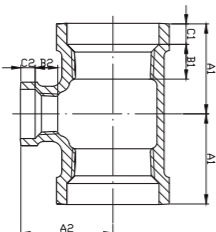

Size/规格	Inch	2X1/2	2X3/4	2X1	2X1 1/4	2X1 1/2
	mm	50X15	50X20	50X25	50X32	50X40
Dim./尺寸 (mm)	A1	49	51.5	54.5	59	62
	B1	20	20	20	20	20
	C1	11	11	11	11	11
	A2	55	58	60	63	64.5
	B2	11	13	15	17	18
	C2	7	8	9	10	10

### 130R

Reducing Tee

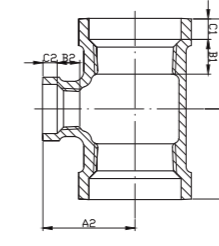

Size/规格	Inch	3X3/4	3X1	3X1 1/4	3X2	4X3/4
	mm	80X20	80X25	80X32	80X50	100X20
Dim./尺寸 (mm)	A1	60	63	68	77	68
	B1	25.5	25.5	25.5	25.5	28.5
	C1	13	13	13	13	14
	A2	74	76	79	84	88
	B2	13	15	17	20	13
	C2	8	9	10	11	8

### 130R

Reducing Tee

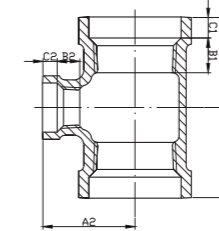

Size/规格	Inch	4X1	4X1 1/4	4X2	4X3	6X3
	mm	100X25	100X32	100X50	100X80	150X80
Dim./尺寸 (mm)	A1	71	75	83.5	97	107.5
	B1	28.5	28.5	28.5	28.5	33
	C1	14	14	14	14	15
	A2	95	96	97.5	104	133.5
	B2	15	17	20	25.5	25.5
	C2	9	10	11	13	13

### 130R

Reducing Tee

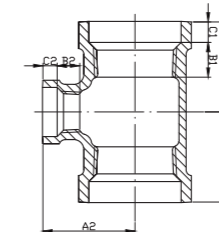

Size/规格	Inch	6X4	3/4X1 1/2X1/2			
	mm	150X100	20X15X15			
Dim./尺寸 (mm)	A1	119.5	38.5			
	B1	33	13			
	C1	15	8			
	A2	139.5	38			
	B2	28.5	11			
	C2	14	7			
A3		35.5				

### 180R

Reducing Cross

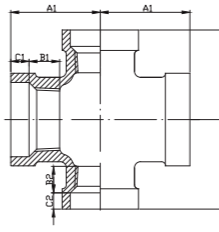

Size/规格	Inch	1X1/2	1 1/4X3/4	1 1/4X1	1 1/2X1/2	1 1/2X3/4
	mm	25X15	32X20	32X25	40X15	40X20
Dim./尺寸 (mm)	A1	41	46	50	46	48
	B1	15	17	17	18	18
	C1	9	10	10	10	10
	A2	41	49	51	49	52
	B2	11	13	15	11	13
	C2	7	8	9	7	8

### 180R

Reducing Cross

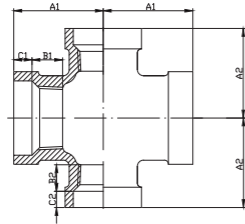

Size/ 规格	Inch	11/2X1	2X3/4	2X1	3X3/4	3X1
	mm	40X25	50X20	50X25	80X20	80X25
Dim./ 尺寸 (mm)	A1	52	51.5	54.5	60	63
	B1	18	20	20	25.5	25.5
	C1	10	11	11	13	13
	A2	54.5	58	60	74	76
	B2	15	13	15	13	15
	C2	9	8	9	8	9

### 180R

Reducing Cross

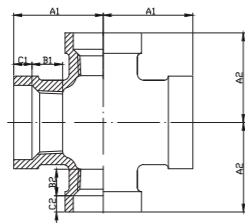

Size/ 规格	Inch	3X11/4	4X3/4	4X1	4X11/4	6X3
	mm	80X32	100X20	100X25	100X32	150X80
Dim./ 尺寸 (mm)	A1	68	68	71	75	107.5
	B1	25.5	28.5	28.5	28.5	33
	C1	13	14	14	14	15
	A2	79	88	90	96	133.5
	B2	17	13	15	17	25.5
	C2	10	8	9	10	13

### 220

Socket

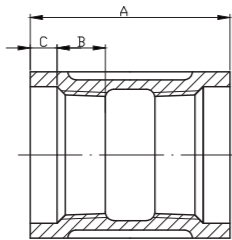

Size/ 规格	Inch	1/2	3/4	1	11/4	11/2
	mm	15	20	25	32	40
	mm	48	54	60	69	74.5
Dim./ 尺寸 (mm)	B	11	13	15	17	18
	C	7	8	9	10	10
	C	7	8	9	10	10
Size/ 规格	Inch	2	3	4	6	
	mm	50	80	100	150	
	mm	86	106.5	121.5	146.5	
Dim./ 尺寸 (mm)	A	86	106.5	121.5	146.5	
	B	20	25.5	28.5	33	
	C	11	13	14	15	

### 241

Bushing

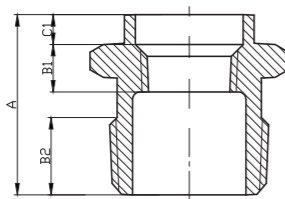

Size/ 规格	Inch	3/4X1/2	1X1/2	1X3/4	11/4X3/4	11/4X1
	mm	20X15	25X15	25X20	32X20	32X25
	A	38	42	42	49	50
	B1	11	11	14.5	13	17
Dim./ 尺寸 (mm)	C1	7	7	7	8	9
	B2	14.5	17	17	19	19
	B2	14.5	17	17	19	19
Size/ 规格	Inch	11/2X3/4	11/2X1	11/2X11/4	2X3/4	2X1
	mm	40X20	40X25	40X32	50X20	50X25
	A	49	50	51	56	57
	B1	13	15	19	13	15
Dim./ 尺寸 (mm)	C1	8	9	10	8	9
	B2	19	19	19	22	22
	B2	19	19	19	22	22

### 241

Bushing

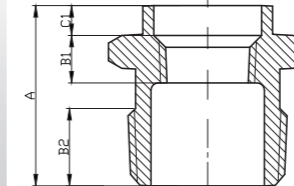

Size/ 规格	Inch	2X11/4	2X11/2	3X1	3X11/2	3X2
	mm	50X32	50X40	80X25	80X40	80X50
Dim./ 尺寸 (mm)	A	58	58	66	67	68
	B1	17	18	15	18	20
	C1	10	10	9	10	11
	B2	22	22	31	31	31
	B2	22	22	31	31	31
Size/ 规格	Inch	4X3	6X3	6X4		
	mm	100X80	150X80	150X100		
Dim./ 尺寸 (mm)	A	78	93	94		
	B1	25.5	25.5	28.5		
	C1	13	13	14		
	B2	36	41	41		

### 280

Hexagon Nipple

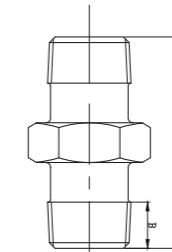

Size/ 规格	Inch	1/2	3/4	1	11/4	11/2
	mm	15	20	25	32	40
Dim./ 尺寸 (mm)	A	58	64	71	80	81
	B	13	14	16	19	19
Size/ 规格	Inch	2	3	4	6	
	mm	50	80	100	150	
Dim./ 尺寸 (mm)	A	94	110	130	146	
	B	23	29	35	40	

### 291

Plug

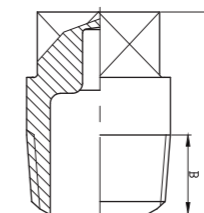

Size/ 规格	Inch	1/2	3/4	1	11/4	11/2
	mm	15	20	25	32	40
Dim./ 尺寸 (mm)	A	30	34.5	40	44.5	46.5
	B	15	16.5	19	21.5	21.5
Size/ 规格	Inch	2	3	4	6	
	mm	50	80	100	150	
Dim./ 尺寸 (mm)	A	51.5	65	76	87.5	
	B	25.5	33	39	43.5	

### 300

Cap

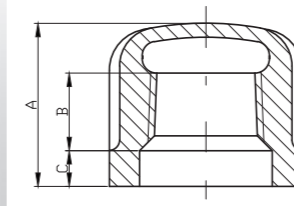

Size/ 规格	Inch	1/2	3/4	1	11/4	11/2
	mm	15	20	25	32	40
Dim./ 尺寸 (mm)	A	28	33	38	41	44
	B	11	13	15	17	18
	C	7	8	9	10	10
Size/ 规格	Inch	2	3	4		
	mm	50	80	100		
Dim./ 尺寸 (mm)	A	49	59	70		
	B	20	25.5	28.5		
	C	11	13	14		

# 529A

## Long Extension Piece

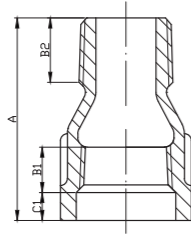

Size/规格	Inch	1/2	3/4	1		
	mm	15	20	25		
Dim./尺寸 (mm)	A	50.5	58	66		
	B1	11	13	15		
	C1	7	8	9		
	B2	15	18	20		

# Malleable Iron Plain End Fittings

## BS Standard

90 Elbow, 90°	130 Tee	130R Reducing Tee	220 Socket	280 Hexagon Nipple
291 Plug	291LM Plug	330 Flat Seat Union		

# 90

## Elbow, 90°

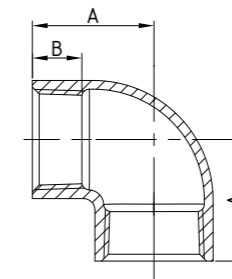

Size/规格	Inch	1/2	3/4	1		
	mm	15	20	25		
Dim./尺寸 (mm)	A	27	32	38		
	B	11	13	15		
Size/规格	Inch					
	mm					
Dim./尺寸 (mm)	A					
	B					

# 130

## Tee

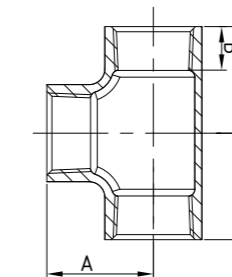

Size/规格	Inch	1/2	3/4	1		
	mm	15	20	25		
Dim./尺寸 (mm)	A	27	32	38		
	B	11	13	15		
Size/规格	Inch					
	mm					
Dim./尺寸 (mm)	A					
	B					



### 130R

Reducing Tee

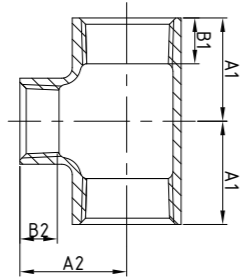

Size/规格	Inch	3/4X1/2	1X3/4			
	mm	20X15	25X20			
Dim./尺寸 (mm)	A1	29.5	31.5			
	B1	13	15			
	A2	30.5	33			
	B2	11	13			

### 220

Socket

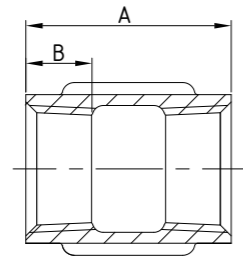

Size/规格	Inch	1/2	3/4	1	1 1/2	
	mm	15	20	25	40	
Dim./尺寸 (mm)	A	34	37	40	44	
	B	11	13	15	18	
Size/规格	Inch					
	mm					
Dim./尺寸 (mm)	A					
	B					

### 280

Hexagon Nipple

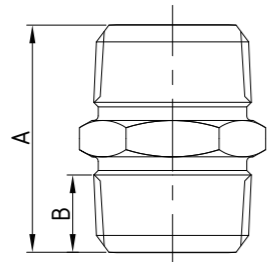

Size/规格	Inch	3/4	1			
	mm	20	25			
Dim./尺寸 (mm)	A	44	50			
	B	15	18			
Size/规格	Inch					
	mm					
Dim./尺寸 (mm)	A					
	B					

### 291

Plug

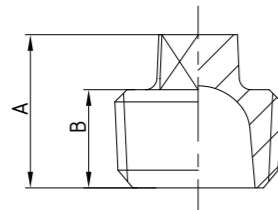
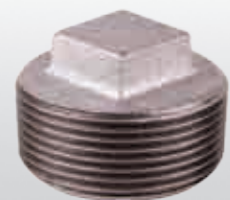

Size/规格	Inch	1/2	3/4	1		
	mm	15	20	25		
Dim./尺寸 (mm)	A	19.5	21	24		
	B	12.5	14	16.5		
Size/规格	Inch					
	mm					
Dim./尺寸 (mm)	A					
	B					

### 291LM

Plug

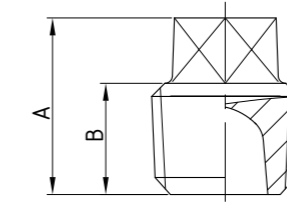
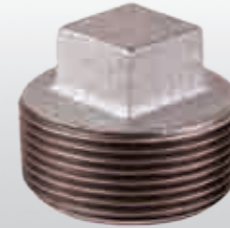

Size/规格	Inch	1/2				
	mm	15				
Dim./尺寸 (mm)	A	25				
	B	15				
Size/规格	Inch					
	mm					
Dim./尺寸 (mm)	A					
	B					

### 330

Flat Seat Union

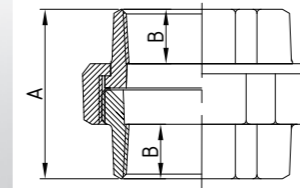

Size/规格	Inch	3/4	1			
	mm	20	25			
Dim./尺寸 (mm)	A	43	45.5			
	B	13	15			
Size/规格	Inch					
	mm					
Dim./尺寸 (mm)	A					
	B					

# Basic Dimension for British and Din Standard Pipe Threads

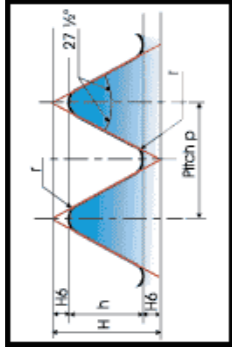
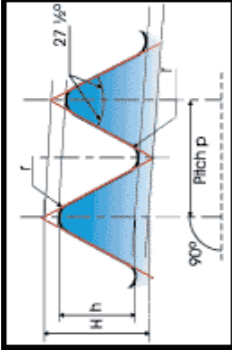
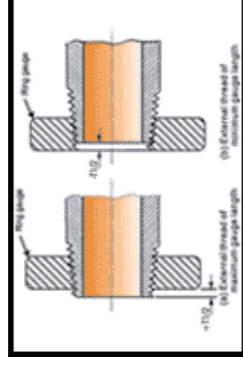

Fig 1 - Parallel thread  
 $H = 0.960491 p$   
 $h = 0.640327 p$   
 $r = 0.137329 p$



Taper 2 - Taper thread  
 $H = 0.960237 p$   
 $h = 0.640327 p$   
 $r = 0.137278 p$



(a) External thread of maximum gauge length  
 (b) External thread of minimum gauge length

## International Standard ISO7/1, Pipe Threads Dimensions

1	2	3	4	5	6			7	8	9		10	11	12	13	14	15	16		17		
					Diameters at gauge plane					Gauge Length (external thread)								Tolerance on position of gauge			Length of useful external thread not less than	
					Major (gauge diameter) d	Pitch d2	Minor d1			Nominal	Tolerance ±1/2							Turns of threads	Minimum		Maximum	For Nominal gauge length
1/8	28	0.907	0.581	9.728	9.147	8.566	4	0.9	1	1.1	1.1/4	6.5	7.4	5.6								
1/4	19	1.337	0.856	13.157	12.501	11.445	6	1.3	1	1.7	1/4	9.7	11	8.4								
3/8	19	1.337	0.856	16.662	15.806	14.95	6.4	1.3	1	1.7	1/4	10.1	11.4	8.8								
1/2	14	1.814	1.162	20.955	19.793	18.631	8.2	1.8	1	2.3	1/4	13.2	15	11.4								
3/4	14	1.814	1.162	26.441	25.279	24.117	9.5	1.8	1	2.3	1/4	14.5	16.3	12.7								
1	11	2.309	1.479	33.249	31.77	30.291	10.4	2.3	1	2.9	1/4	16.8	19.1	14.5								
1 1/4	11	2.309	1.479	41.91	40.431	38.952	12.7	2.3	1	2.9	1/4	19.1	21.4	16.8								
1 1/2	11	2.309	1.479	47.803	46.324	44.845	12.7	2.3	1	2.9	1/4	19.1	21.4	16.8								
2	11	2.309	1.479	59.614	58.135	56.656	15.9	2.3	1	2.9	1/4	23	25.7	21.1								
2 1/2	11	2.309	1.479	75.184	73.705	72.226	17.5	3.5	1 1/2	3.5	1/2	26.7	30.2	23.2								
3	11	2.309	1.479	87.884	86.405	84.926	20.6	3.5	1 1/2	3.5	1/2	29.8	33.3	26.3								
4	11	2.309	1.479	113.03	111.551	110.072	25.4	3.5	1 1/2	3.5	1/2	35.8	39.3	32.3								
5	11	2.309	1.479	138.43	136.951	135.472	28.6	3.5	1 1/2	3.5	1/2	40.1	43.6	36.6								
6	11	2.309	1.479	163.83	162.351	160.872	28.6	3.5	1 1/2	3.5	1/2	40.1	43.6	36.6								

Note: This information is selected from the International Standard ISO7/1:2000: Pipe threads where pressure - tight joints, Table Table 1